

Support Systems for Heavy Industrial & HVAC



Strut *Foot*

About Us

Our manufacturing division has been involved in offsite manufacturing for the M&E building service sector for over 20 years. In the last 10 years we have developed the StrutFoot system for the support of HVAC equipment, cable management and mechanical services.

Contents

- StrutFoot Plastic Feet
- StrutFoot Dual Foot & Basket Feet
- StrutFoot H Frame Kits
- StrutFoot Base & Plus
- StrutFoot LD Frames
- StrutFoot HD Frames
- StrutFoot SFR Rubber Feet
- StrutFoot SFR Mini Split & Angled Pads
- StrutFoot SFR Vibro & AV Pads
- StrutFoot Cantilever Kit
- StrutFoot Fleeces & Mounting Blocks
- StrutFoot Duct Adjuster
- StrutFoot Angled Leg Assembly
- StrutFoot Cushion Clamps
- StrutFoot Beams
- StrutFoot Quads
- StrutFoot StepOver
- StrutFoot Bespoke Access
- StrutFoot Case Study

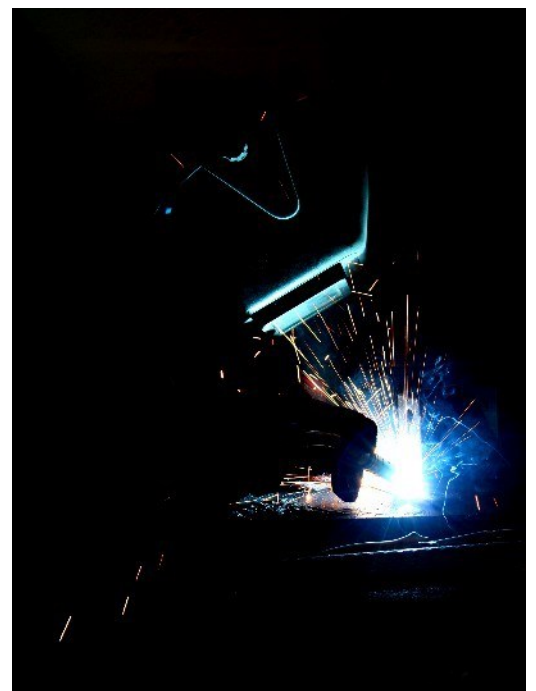

StrutFoot Around the World



Countries:

Australia, Austria, Belarus, Belgium, Bulgaria, Canada, China, Czech Rep, Denmark, Dubai, Estonia, Finland, France, Germany, Greece, Hungary, Ireland, India, Italy, Morocco, Netherlands, New Zealand, Nigeria, Poland, Portugal, Romania, Russia, Saudi Arabia, Slovenia, South Africa, Spain, Switzerland, United Kingdom & United States of America



Code	Description (mm)	Dimensions (mm) (L x W x H)	S.W.L (KG Per Foot)
SF3200	R200 Plastic Foot	200 x 200 x 120	150
SF3105	R305 Plastic Foot	305 x 305 x 120	175
SF3505	R500 Plastic Foot	500 x 500 x 120	250

StrutFoot's plastic feet are made from 100% recycled High Density Polyethylene (HDPE). Each of our plastic feet are complete with an anti-vibration pad which are pre-attached. These help prevent polymer migration between the roof and the plastic. They can be used for different types of strut/box; 41x41mm, 41x21mm and 40x40mm.

Material Testing Report

Material	High Impact HDPE
Colour	Black
Company	Engineering Plastics R&D Centre
Test date	03.05.2015
Test conditions	Room temperature 23 deg for 24 hrs, humidity 50+/-5%
Injection temp	230-250 deg C
Melt index	10.2g/10min

Test Item	Units	Standard	Value
Tensile Strength	MPa	GB/T1040	16.9
Elongation at break	%	GB/T1040	13.7
Bending strength	MPa	GB9341	18.8
Notched Izod impact strength	KJ/m ²	GB/T1843	7.7

StrutFoot R400 Dual Foot

The R400 Dual Foot has been designed to fit both 80x80 Box Section and 41x82 back to back channel. This foot has been designed and manufactured in house to offer flexibility in framing system installation.

It is made with a High Density Polyethylene (HDPE) plastic making it lightweight and very robust. There is an anti-vibration foam pad pre-attached meaning there is no penetration of/or reaction with the waterproof roof membrane.

Product Information

Part No	Feet Size (mm)	Product Weight (kg)	S.W.L (kg)
R400D	400	3.97	1000

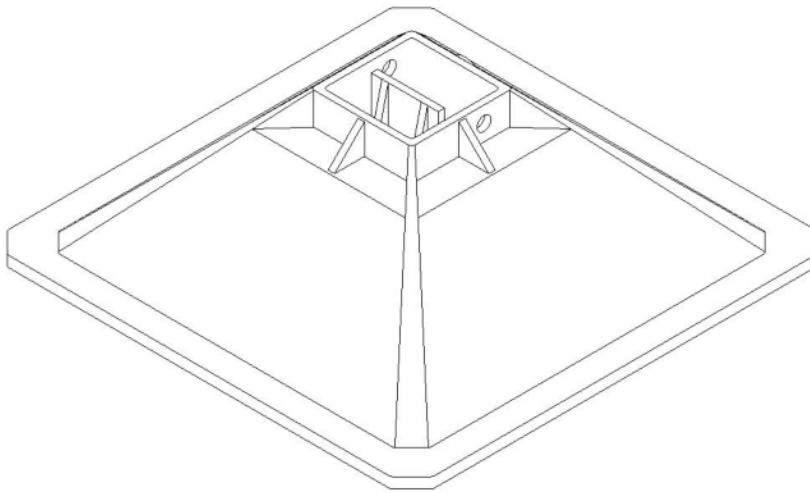

StrutFoot Basket Feet

StrutFoot have developed a new plastic foot to speed up the installation of basket tray. We have two products with a clearance of 30mm and one with a 80mm clearance.

It is made with a High Density Polyethylene (HDPE) plastic making it lightweight and very robust, click and go.

Product Information

Part No	Feet Size (mm)	Feet Height (mm)
SF3030	140	30
SF3080	140	80



The H Frame Kit is a quick and easy solution to support all cable management, ducting and pipe work.

H Frames are supplied in box form.

They are designed to use channel which is not included. As a module, our manufacturing department can fabricate the H Frames in house to speed up the process of installation on site.

H Frame Kit Includes

Product	Quantity
Plastic Feet	x 2
Fixing Kit	x 1

Product Information

Part No	Feet Size (mm)	Product Weight (kg)	Frame S.W.L (kg)
SF3305	305	4.1	350
SF3500	500	10	500

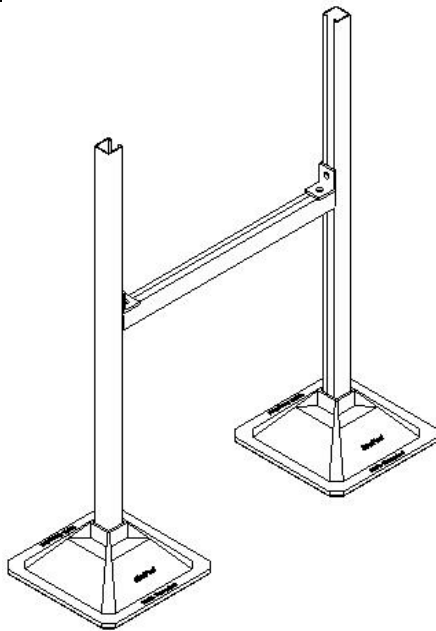

- High Density Polyethylene (HDPE)
- Designed to fit channel (not included)
- No penetration of waterproof roof membrane
- Anti-vibration pads pre attached to feet
- Off site cutting & delivering service available
- Available in 305mm & 500mm





- Easy to adapt & extend to suit most installations and can be extended to any length.
- Channel framework provides strength & convenience for cable management installation
- Cross compatibility with all channel type brackets
- Fast & economical systems for mounting M&E services, Air Conditioning & Refrigeration on flat roofs
- Easy to install for individual products or complete installations
- No penetration of waterproof roof membrane
- Non drill system

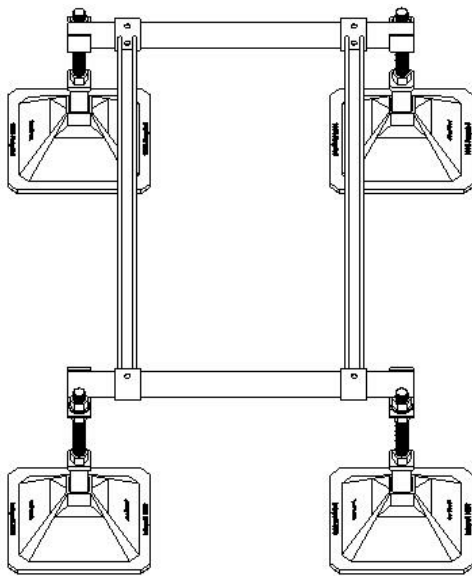

StrutFoot Base System

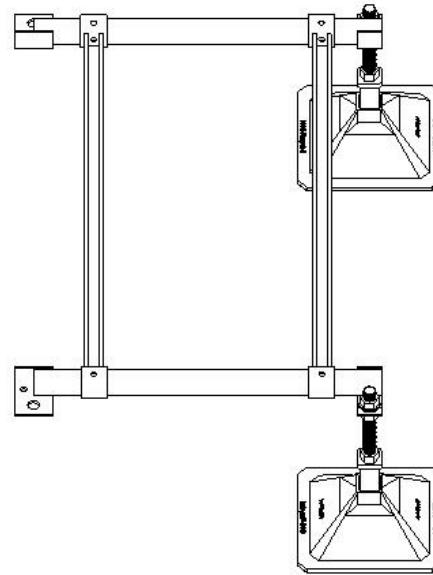

StrutFoot Plus System

StrutFoot Support System - Technical Information

Part No	Product Description	Complete Leg Assembly	Sliding Arm	Side Rails (mm)	Sliding Arms (mm)	Product Weight (kg)	Max S.W.L (kg)
SF1002	StrutFoot Base	4	2	1000	1300	32	700
SF1004	StrutFoot Plus	2	2	1000	1300	26	350

Welding to ISO 9606-1

Galvanising to BS EN ISO 1461:1999

CE 1090

ISO 9001 Quality & ISO 14001

Environmental Certification Number 1753

Channel to BS6946



**The StrutFoot™ Flat Roof Support System,
offering total flexibility for design, layout & installation.**

- Channel framework provides strength & convenience for cable management installation
- Cross-compatibility with all channel type brackets
- Fast & economical systems for mounting M&E services, Air Conditioning & Refrigeration on flat roofs
- Easy to install for individual products or complete installations
- No penetration of waterproof roof membrane
- Standard & bespoke configurations
- Anti-Vibration pads pre attached to feet
- Feet & blocks available separately

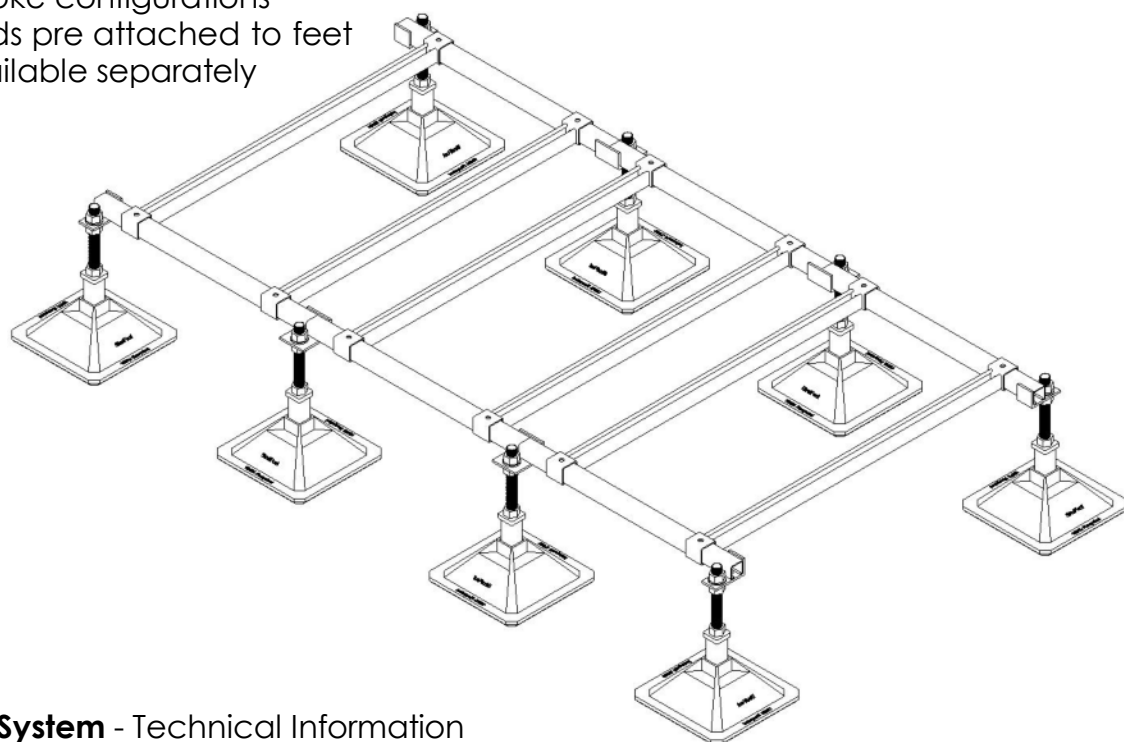

StrutFoot Support System - Technical Information

Part No	Product Description	Complete Leg Assembly	Sliding Arm	Side Rails (mm)	Sliding Arms (mm)	Product Weight (kg)	Max S.W.L (kg)
SF1302	StrutFoot 2	4	2	1000	1300	28	700
SF1304	StrutFoot 4	6	4	2000	1300	49	1050
SF1306	StrutFoot 6	8	6	3000	1300	70	1400
SF1308	StrutFoot 8	10	8	4000	1300	91	1750
SF1310	StrutFoot 10	12	10	5000	1300	113	2100
SF1312	StrutFoot 12	14	12	6000	1300	134	2450



StrutFoot's HD system is predominantly used for large Air Handling Units and Chillers. Each system is manufactured in house enabling us to make the design suit the unit being supported.

The system has been designed using heavy duty 41x82 hot dipped galvanised channel. It has been designed for heavy loads, cable management and pipe work which can all be easily installed into the channel system.

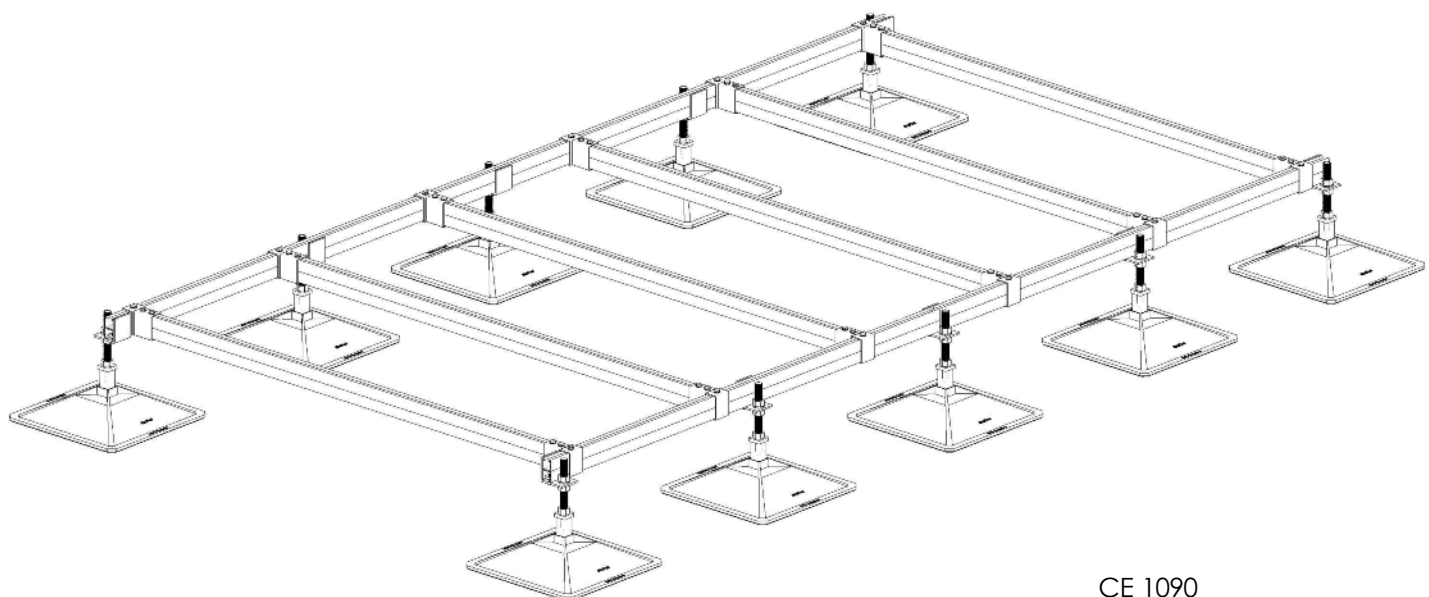

Welding to ISO 9606-1
 ISO 9001 Quality & ISO 14001 Environmental Certification Number 1753

Galvanising to BS EN ISO 1461:1999

CE 1090
 Channel to BS6946



StrutFoot SFR Rubber Feet

The SFR range of recycled rubber feet has been designed to carry loads on non-penetrable roofs; which include pipe work, cable management and small units. We offer the SFR feet with Aluminium channel to ensure a high corrosion resistance.

Part No	Model	Length (mm)	Width (mm)	Height (mm)	Max Loading Per Foot (kg)
SF4025	SFR250	250	180	95	160
SF4040	SFR400	400	180	95	240
SF4060	SFR600	600	180	95	450
SF4010	SFR1000	1000	180	95	645
SF4525	SFR250 Low	250	130	50	160
SF4540	SFR400 Low	400	130	50	240

Part No	Model	Length (mm)	Width (mm)	Height (mm)	Max Loading Per Foot (kg)
SF1560	SFR600 High Block	600	130	150	450
SF1512	SFR1200 High Block	1200	130	150	645

MATERIAL SPECIFICATION

SBR-Recycled Rubber. Bound using a ratio of high quality moisture curing Polyurethane Pre-Polymer. BS7188:1989+A2:2009 and BS EN1176-7:2008

METAL PROFILE

Aluminium strut 41mm x 21mm profile compatible with strut fixings.

WORKING CONDITIONS

Suitable for internal or external applications in temperatures between -40°C to +80°C. BSEN60068-2-14

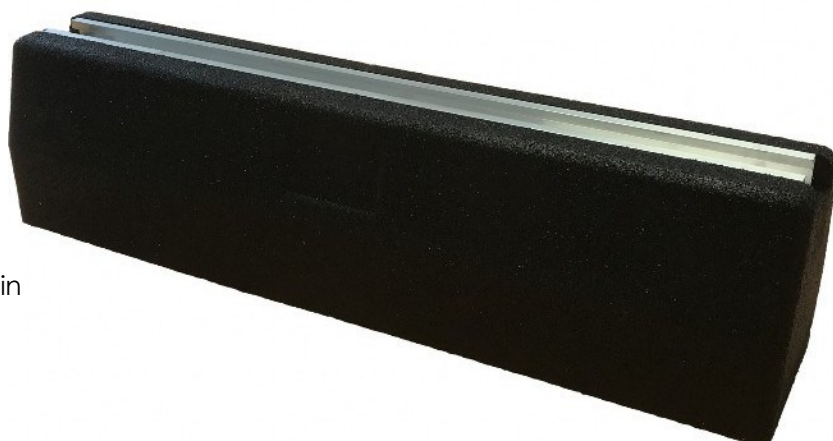

StrutFoot SFR Mini Split Kits

Part No	Description	Length (mm)	Width (mm)	Height (mm)	S.W.L per Kit (kg)	Packaged Weight (kg)
SF4044	Mini Split Kit SFR 400	400	180	95	480	9.5
SF4066	Mini Split Kit SFR 600	600	180	95	900	13
SF4011	Mini Split Kit SFR 1000	1000	180	95	1290	21.6

Kit Includes

Rubber Feet	x 2
Fixing Kit	x 2



StrutFoot Angled Rubber Pads

Part No	Description	Length (mm)	Width (mm)	Packaged Weight (kg)
SF4071	SFR 305 2.5 Degree	305	305	1.9
SF4072	SFR 500 2.5 Degree	500	500	6
SF4073	SFR 305 5 Degree	305	305	1.6
SF4074	SFR 500 5 Degree	500	500	7.5

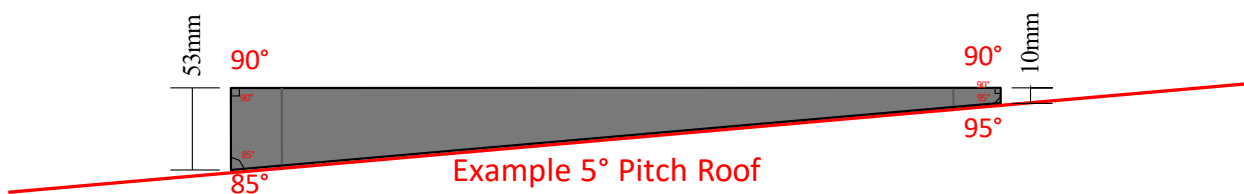

Both of the StrutFoot recycled rubber mats can be laid directly onto the roof to reduce the noise pollution going through the frame onto the roof.

They can be used as a walkway system or placed under any of our StrutFoot systems to separate the foam pad from the roof.

StrutFoot SFR Vibro Mats

Part No	Description	Length (mm)	Width (mm)	Height (mm)	Packaged Weight (kg)
SF4091	SFR Vibro Mat 330	330	330	45	4
SF4092	SFR Vibro Mat 500	500	500	45	7.5



StrutFoot SFR AV Pads

Part No	Description	Length (mm)	Width (mm)	Height (mm)	Packaged Weight (kg)
SF4081	SFR 300mm AV Pad	300	300	6	0.5
SF4082	SFR 500mm AV Pad	500	500	6	0.85



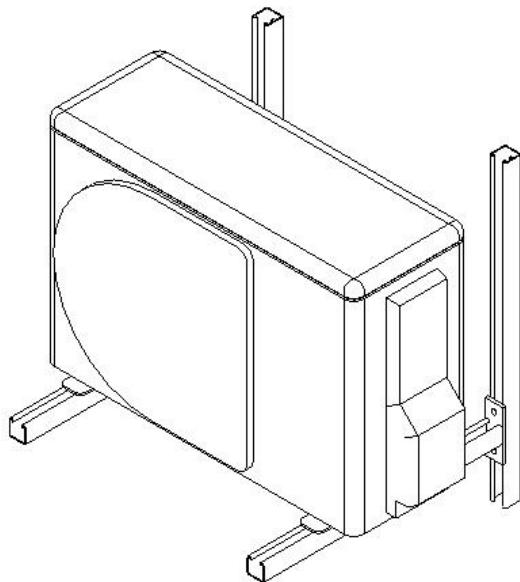

StrutFoot's cantilever kits are available in 3 different sizes. They are a quick and easy solution to supporting air conditioning units and heat pump systems to the wall. These kits are supplied flat packed with all fixings required.

Part No	Description	Length (mm)	Width (mm)	Height (mm)	S.W.L per arm (kg)	Packaged Weight (kg)
SF6001	Cantilever Arm Kit - 450mm	450	41	750	250	8
SF6002	Cantilever Arm Kit - 600mm	600	41	750	190	9
SF6003	Cantilever Arm Kit - 750mm	750	41	750	150	10

Kit Includes

Cant Arms	x 2
750mm Strut Uprights	x 2
M10x25, M10FW, M10 Channel Nuts	x 8
M8x40 Loose Bolt	x 4
Black PVC End Caps	x 6



Channel B6946

Galvanising BSEN1461

Welding ISO 9606-1

StrutFoot Fleeces



The StrutFoot fleece has been designed to suit both our plastic feet and rubber feet. They are used for in between asphalt and PVC roof membrane surfaces. This will therefore help prevent polymer migration between the plastic and rubber products.

Product Information

Part No.	Length (mm)	Width (mm)	Thickness (mm)
SF9010	215	215	4
SF9011	315	315	4
SF9012	515	515	4
SF9013	250	200	4
SF9014	400	200	4
SF9015	600	200	4
SF9017	1000	200	4

StrutFoot Mounting Blocks

The StrutFoot mounting block is a solution for supporting small condensing units on a roof without penetrating the roof membrane. They are made from recycled PVC plastic and are UV stabilised.

Product Information

Part No.	Length (mm)	Width (mm)	Safe Working Load (kg)
CB350	350	105	240
CB450	450	105	240
CB600	600	105	240
CB1000	1000	105	240



They are manufactured in house enabling us to also offer bespoke sizes upon request.

87% quicker than standard installations

StrutFoot's adjustable ducting support system is now available for both our plastic feet and rubber feet. They both offer flexibility, a non-penetrative system and quick installation. The height of the duct adjuster can easily be changed using the thumb screw provided.

Product Information - Plastic Feet

Part No.	Feet Size (mm)	Quantity	Packaged Weight (kg)
SF5822	305	x 5	10
SF5844	500	x 2	13.5



StrutFoot's adjustable ducting support system is now available for our standard rubber feet. The component is sold separately to the rubber foot.

- Non-penetrative duct support
- Quick and easy to install
- Rubber and plastic feet available
- Plastic feet incl Adhered anti-vibration pads
- Comfortable height adjustment using thumb screw
- Static max. Load 80kg
- 8mm stud for ducting support rings and clamps



StrutFoot's new adjustable angled insert allows you to install on a pitched roof up to 10° allowing the framework to sit square. It has been developed so it can be used in both our R200, R305 & R500 plastic foot so it is universal with products already stocked by our suppliers.

It is made from galvanised steel making it suitable for roof applications. It is suitable for both 41x41mm channel and 40x40 box section.

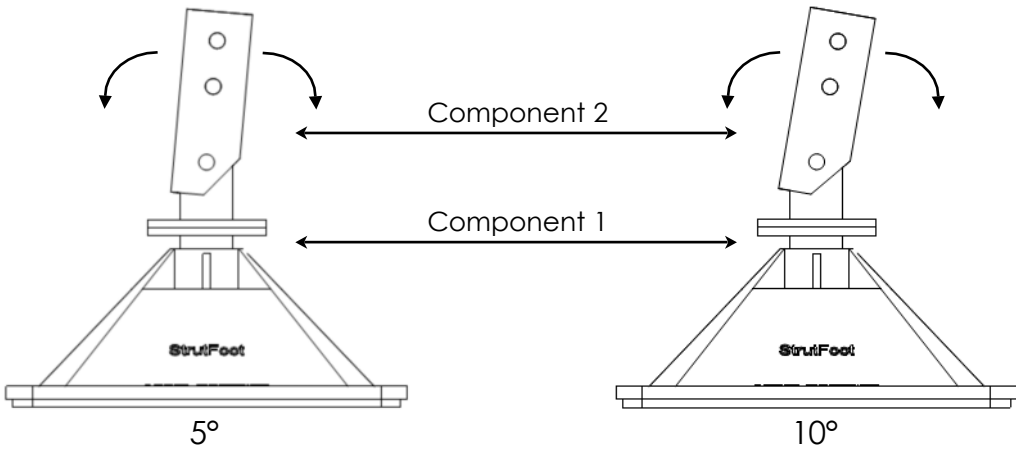

Kit Includes

- R305/500 Plastic Foot
- Component 1
- Component 2



StrutFoot's cushion clamps are used to support copper refrigeration tube. They are supplied with a polymer insert which allows for a strong grip and absorbs shock and vibration running through the tube. A zinc dichromate plating ensures a corrosion resistance.

Part Code	Pipe Diameter	Pack QTY
SF004	1/4"	10
SF006	3/8"	10
SF008	1/2"	10
SF010	5/8"	10
SF012	3/4"	10
SF014	7/8"	10
SF018	1 1/8"	10
SF022	1 3/8"	10
SF026	1 5/8"	10
SF034	2 1/8"	10



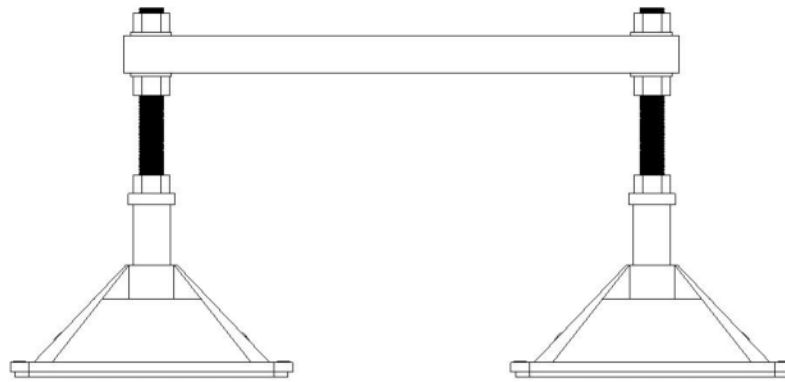

The StrutFoot Beam is an adjustable heavy duty support system which is typically used with heavy Air Handling Units (AHU's) or when existing steel beams need to be picked up on the roof.

Part No.	Feet Size (mm)	Beam Size (mm)	Product Weight (kg)	Frame S.W.L (kg)
SFBEAMR305	305	600	10	350
SFBEAMR500	500	600	13	500

- Adjustable heavy duty support system
- Used to pick up existing support beams
- Used to support AHU's
- Supplied with fixings
- Supplied to fit unit size
- Hot dipped galvanised (HDG) framework
- Available in 305 and 500mm plastic feet

StrutFoot Beam Includes

Product	Quantity
Leg Assembly	x 2
Beam	x 1
Brackets	x 2





StrutFoot's quad system is a quick and easy solution to support large/heavy AHU's, chillers and plant rooms.

All the framework on each Quad system is HDG for outdoor use. It can be supplied using either our R305 or R500 plastic feet.

We manufacture a welded framework for both our quad to ensure strength and minimize the deflection in the strut.

StrutFoot Quad Adjustable

Part No.	Description	Feet Size (mm)	S.W.L (kg)
SF6305	StrutFoot Quad R305 Adjustable	305	700
SF6500	StrutFoot Quad R500 Adjustable	500	1000



StrutFoot offer a full range of Stepovers to their customers. Each Stepover is complete with 1000mm wide steps, 1000x1000mm platform and handrail.

With our in house design and manufacturing, StrutFoot can supply and install bespoke access to meet the customers specification.

The framework on all of our access is HDG ensuring it is suitable for roof applications. All of the leg assemblies supplied are adjustable and supplied with our R305 or R200 plastic feet.

All of the below systems are available from stock and easily installed.

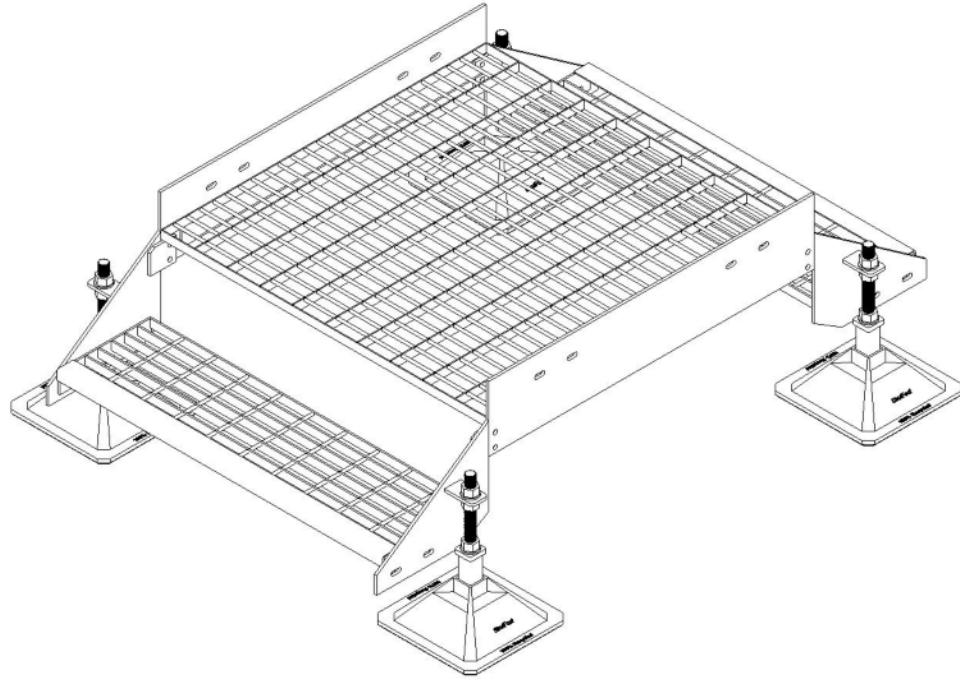

StrutFoot Stepovers

Part No.	Description	Feet Size (mm)	Platform Size (mm)
SF8010	SFA111 - 1 Step Stepover	305	1000x1000
SF8020	SFA212 - 2 Step Stepover	305	1000x1000
SF8030	SFA313 - 3 Step Stepover	305	1000x1000
SF8040	SFA414 - 4 Step Stepover	305	1000x1000

StrutFoot Platform

Part No.	Description	Feet Size (mm)	Platform Size (mm)
SF8050	SFA555 - StrutFoot Platform	305	1000x1000

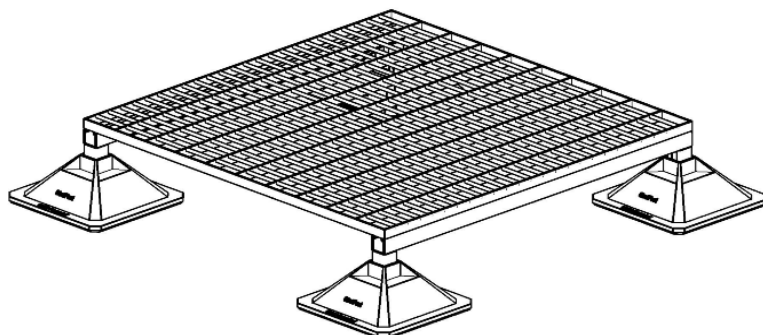

StrutFoot are the only supplier who currently design and manufacture bespoke access in house.

Material:

- HDG Framework
- HDG/GRP open mesh flooring
- Handrail - key clamps & box section available upon request

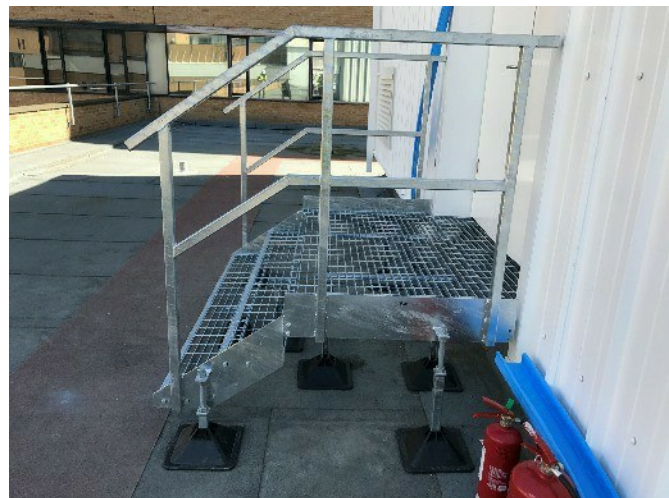
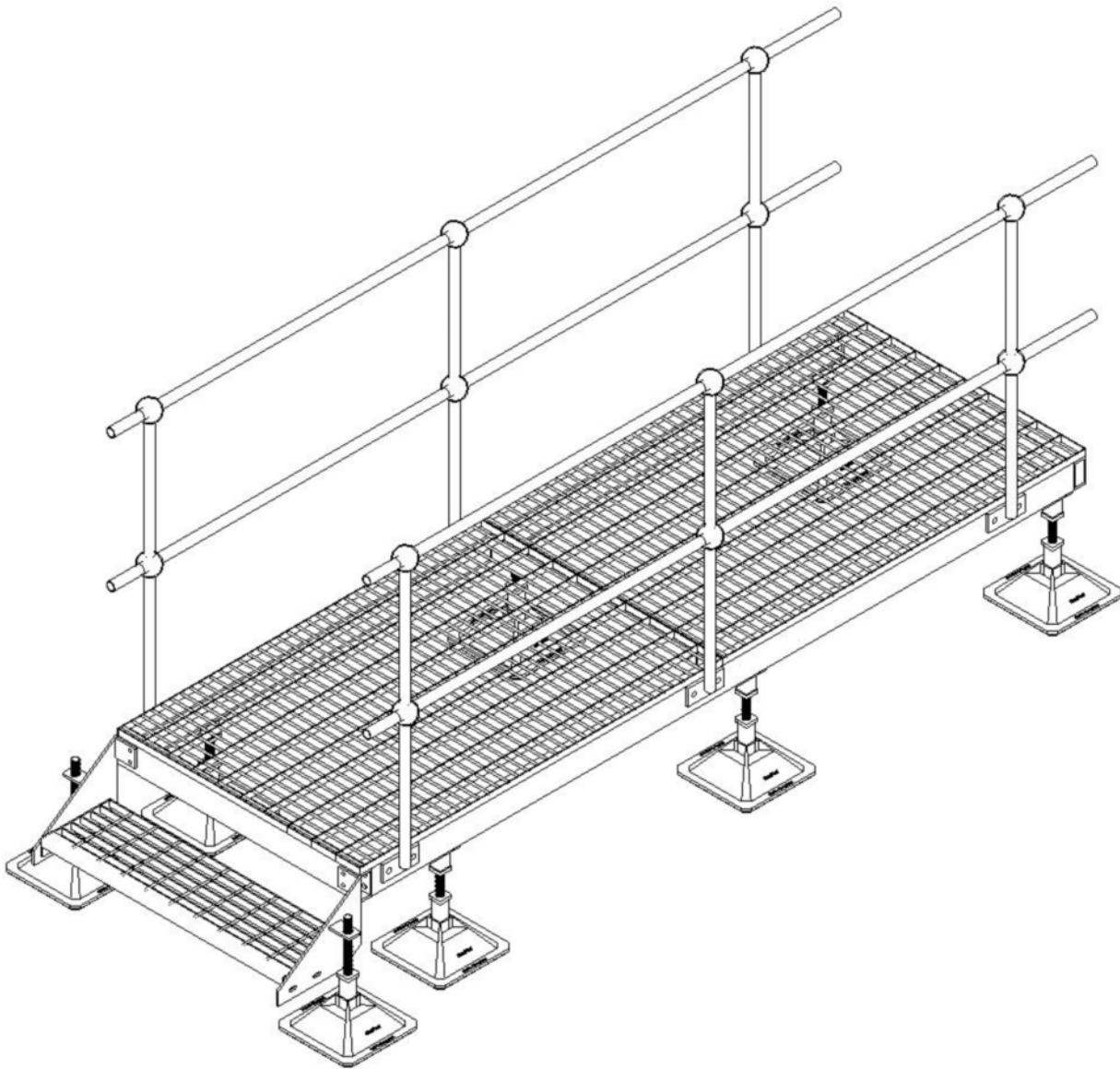



StrutFoot originally supplied a HD frame to support a large AHU on the project. We were then asked to quote, design and install a bespoke platform and three bespoke Stepovers for a project in Southampton.

The client sent us all the technical information regarding requirements for the access; e.g. dimensions and clearance required.

We managed to get all the access manufactured, galvanised, delivered and installed within 23 days.





StrutFoot were tasked with designing roof top supports for AHU's, chillers and ductwork for a project in London.

The client issued us with the drawings and technical specifications for the project. Following a site survey we were able to offer a cost effective solution, designed, engineered and delivered to site in 5 working days to site.



After the installation of the StrutFoot frames, the final inspection was supervised by our Site Manager. The client was pleased with the solutions provided.

The customer requested access to fit just above the ductwork which was already situated on the roof.

Everything was again manufactured in house and delivered to site.

StrutFoot then sent out an installation team to build the framework which was completed in 5 working days.



Cable Management PTY Ltd is an independently owned company that provides a range of speciality cable management products & solutions to the Mining, Heavy Industrial and Renewables markets across Africa. With extensive experience in the cable management and mechanical supports sectors, we provide a high level of technical support and advice on the latest innovations in system design, safety and value add applications. We offer extremely innovative solutions for even the most arduous & complex cable support application that would fall outside the scope of standard cable management products.

We distribute across the African continent and are able to service the most complex project site and remote locations. We also offer localised training on our products for all relevant applications.

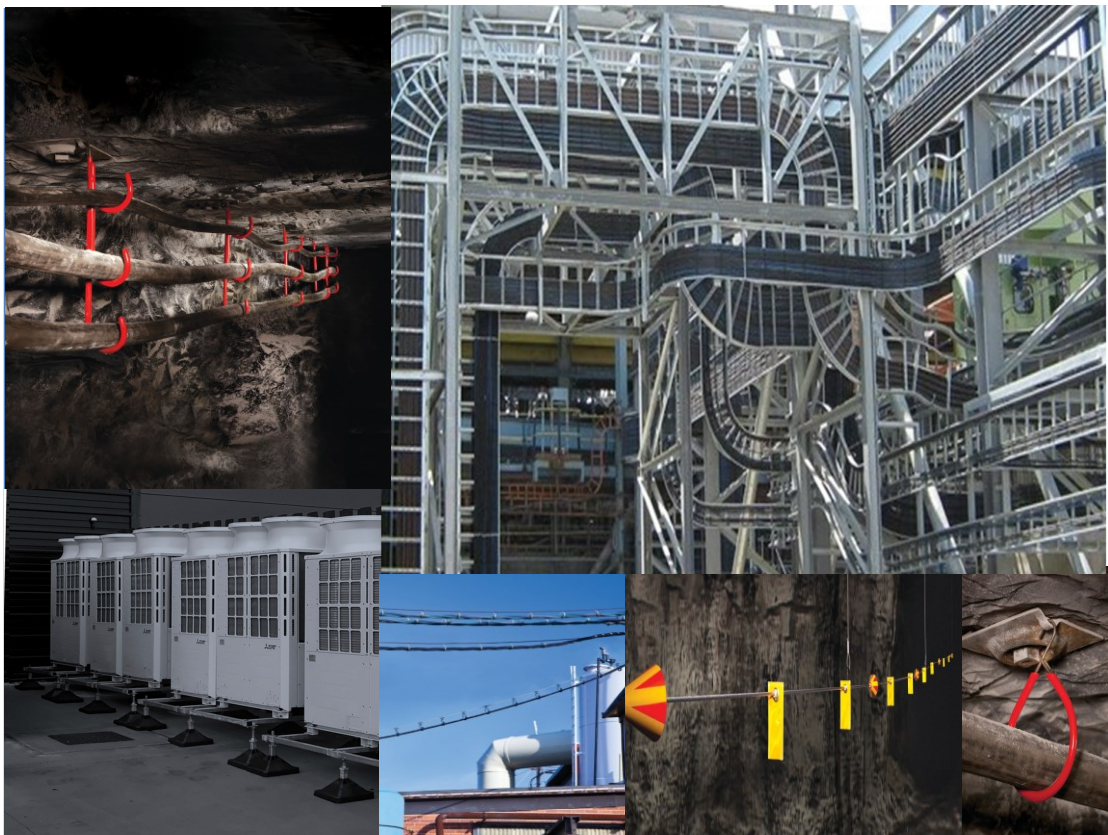

Cable Management Pty Ltd

Tel: +27 100 130372

sales@cablemanagement.co.za

Offices in Johannesburg & Cape Town

Distribution in Botswana, DRC, Ghana, Kenya, Malawi,
Mozambique, Namibia, Tanzania, Uganda, Zambia, Zimbabwe.

CM **CABLE**
MANAGEMENT
cable support solutions

www.cablemanagement.africa